

CEMENT CORPORATION OF INDIA LIMITED
TANDUR CEMENT FACTORY
P.O: CCI-TANDUR - 501 158, VIKARABAD Dist, (TELANGANA)
CIN No. U74899DLI965GOI004322

E-Mail: mm_tdo@ccilttd.in

Website: www.ccilttd.in

NIT No: TCF/MM/4044/23/RR

Date: 27.05.2024

NOTICE INVITING E-TENDER
(Only through e-procurement)

Online electronic bids through Electronic Tendering System (ETS) are invited from Manufacturers & Dealers having adequate experience for: **SUPPLY OF SUPPLY OF INDUSTRIAL TUBE AXIAL FAN.**

The complete set of tender documents is available on websites www.ccilttd.in, www.etenders.gov.in/eprocure/app

E-TENDER No.	TCF/MM/4044/23/RR
MODE OF TENDER	e-Procurement System (Online Part A - Techno-Commercial Bid and Part B - Price Bid) through www.etenders.gov.in/eprocure/app
Earnest Money Deposit	Rs. 12,000.00(Rupees Twovel Thousand only) by NEFT/RTGS in favor of M/s. CEMENT CORPORATION OF INDIA LIMITED Bank : SBI, Karankote Branch Bank A/c. : 62017406489 IFSC Code : SBIN0020446
Date of NIT available to parties to download	From 28.05.2024 (10.00 hrs.) Till 11.06.2024 (14.30 hrs.)
Last date of submission of EMD, valid SSI/NSIC/MSME certificate and other documents required as per tender terms & conditions under covering letter	11.06.2024 (15:00 hrs.)
Date of Starting of e-Tender for submission of on line Techno-Commercial Bid and Price Bid at www.etenders.gov.in/eprocure/app	From 28.05.2024 (10:00 hrs.) Till 11.06.2024 (15:00 hrs.)
Date & time of opening of Part-A (i.e. Techno-Commercial Bid) Part-B Price Bid: Date of opening of Part-B i.e. price bid shall be informed separately	12.06.2024 at 15.30 hrs. To be communicated separately.
Validity of bids	120 days from the date of the techno-commercial bid opening.

Offer is invited for the following on FIRM & FOR destination basis as per details given below:

SCHEDULE OF MATERIAL:

Sl. No.	Description	Unit	Qty.
1	Energy Efficient Industrial Tube Axial Fan for 3200 KW Motor Cooling Duct as per given specification.	Nos	04

- 01) Only those tenders will be considered who fulfill the terms & conditions mentioned in the tender documents.
- 02) The price- bid should be only as per CCI's Price-bid format otherwise the tender is liable for rejection.
- 03) The Overall L-1 Rate will be arrived considering landed cost of the material after GST input credit etc.

List of Annexure

Part - I	Covering letter, Part-I - Instruction to tenderers, available in CCI web site https://www.ccilttd.in/UserFiles/files/GTC2.pdf .
Part-II	Part-II- General terms & conditions , Integrity Pact and Annexures 1 to 9 available in CCI web site https://www.ccilttd.in/UserFiles/files/GTC2.pdf .
Part-III	Part-III- Special Terms & Conditions
Part-IV	Part-IV- Technical Specifications

Please read the Part – I (Instructions to tenderers), Part- II (General Terms & Conditions) available on tender portal of www.cci.ltd.in and Part- III (Special Terms & Conditions) & Part- IV (Technical specifications) of this tender and submit Declaration letter (Annexure-9)duly signed and stamped in letter head of having read and understood the GTC.

IMPORTANT INSTRUCTIONS FOR E-PROCUREMENT

This is an e-procurement event of Cement Corporation of India. You are requested to read the Tender Terms & Conditions of this tender before submitting your online tender. Tenderers who do not comply with the conditions with documentary proof (wherever required) will not qualify in the Tender for opening of price bid.

01)	<p><u>Process of E-Tender:</u></p> <p><u>Registration:</u></p> <p>The process involves vendor's registration with www.etenders.gov.in/eprocure/app Only after registration, the vendor(s) can submit his/their bids electronically. Electronic Bidding for submission of Techno-Commercial Bid as well as Price Bid over the internet will be done. The Vendor should possess Class III signing type digital certificate. Vendors are to make their own arrangement for bidding from a P.C. connected with Internet. Antares Systems Ltd is not responsible for making such arrangement. (Bids will not be recorded without Digital Signature).</p> <p>SPECIAL NOTE: THE PRICE BID AND THE TECHNO-COMMERCIAL BID HAS TO BE SUBMITTED ON-LINE AT www.etenders.gov.in/eprocure/app</p> <p>Vendors are required to register themselves online with www.etenders.gov.in/eprocure/app → 'Register Me' link. Filling up details and creating own user id and password→ Submit.</p> <p>Vendors will receive a system generated mail confirming their registration in their email which has been provided during filling the registration form.</p> <p>Contact person (Cement Corporation of India):</p> <table border="1" data-bbox="248 1279 1455 1518"><thead><tr><th>Name</th><th>Email</th><th>Land Line</th><th>Mobile</th></tr></thead><tbody><tr><td>P Prabakaran, AGM(MM)</td><td>mm_tdo@ccilttd.in</td><td></td><td>07799938023</td></tr><tr><td>Ramanamurthy, DGM (ELECT.)</td><td>tandurcementfactory.electrical@gmail.com</td><td></td><td>07799938101</td></tr><tr><td>C. Amit joseph, DM-MM</td><td>mm_tdo@ccilttd.in</td><td></td><td>07799938185</td></tr></tbody></table> <p>B) System Requirement:</p> <p>Windows 8,10 Professional Operating System, Internet Browser-9,10 &11. Signing type Class 3 digital signature Java JRE 6 and above</p> <p>THE VENDORS ARE ADVISED TO GO THROUGH THE Help Manual LINK AT etenders.gov.in/eprocure/app FOR GENERAL GUIDANCE ABOUT TENDER PROCESS</p>	Name	Email	Land Line	Mobile	P Prabakaran, AGM(MM)	mm_tdo@ccilttd.in		07799938023	Ramanamurthy, DGM (ELECT.)	tandurcementfactory.electrical@gmail.com		07799938101	C. Amit joseph, DM-MM	mm_tdo@ccilttd.in		07799938185
Name	Email	Land Line	Mobile														
P Prabakaran, AGM(MM)	mm_tdo@ccilttd.in		07799938023														
Ramanamurthy, DGM (ELECT.)	tandurcementfactory.electrical@gmail.com		07799938101														
C. Amit joseph, DM-MM	mm_tdo@ccilttd.in		07799938185														
02)	<p>(A) Part-A Techno-Commercial bid will be opened electronically on specified date and time as given in the NIT. Bidder(s) can witness electronic opening of bid.</p> <p>(B) Part-B Price bid will be opened electronically of only those bidder(s) who's Part-A Techno- Commercial Bid is found to be Techno-Commercially acceptable by CCI. Such bidder(s) will be intimated date of opening of Part-B Price bid, through valid email confirmed by them.</p>																

	<p>NOTE:</p> <p>The Tenderers are advised to offer their lowest possible rates taking into account the prevailing market conditions. There would generally be no negotiations hence please submit your most competitive prices while submitting the price bid. However, if the rate is still considered high, action as per prevailing instruction/guideline shall be taken.</p>
03)	All entries in the tender should be entered in online Technical & Commercial Formats without any ambiguity.
04)	In case of failure to access the payment towards cost of tender document & EMD for any reason, the vender, in term, will not have the access to on line e-tender and no correspondence in this respect will be entertained and CCI will not be responsible for any such lapses on this account. Bidder(s) are advised to make remittance of tender fee and EMD through Online well in advance and verify completion of transaction in respect of tender fee and EMD. Vendors are instructed to upload documents in document library. Multiple documents can be uploaded. Maximum size of single document for upload is 5 MB. Once documents are uploaded in the library, vendors can attach documents through Attach Document link against the particular tender. For further assistance please follow instructions of Vendor Help Manual
05)	All notices/corrigendum and correspondence to the bidder(s) shall be sent by email only during the process till finalization of tender by CCI. Hence the bidders are required to ensure that their corporate email I.D. provided is valid and updated at the stage of registration of vendor with CPP (i.e. Service Provider). Bidders are also requested to ensure validity of their DSC (Digital Signature Certificate).
06)	The responsibility of downloading the related corrigenda, if any, will be that of the downloading parties.
07)	E-tender cannot be accessed after the due date and time mentioned in NIT.
08)	<p>Bidding in e-tender & Reverse auction:</p> <p>a) Bidder(s) need to submit necessary EMD and Tender fees (If ANY) to be eligible to bid online in the e-tender. Tender fees are non-refundable. No interest will be paid on EMD. EMD of the unsuccessful bidder(s) will be refunded by CCI.</p> <p>b) The process involves Electronic Bidding for submission of Techno Commercial Bid as well as Price Bid is explained in Help Manual. 1) In all cases, bidder should use their own ID and Password along with Digital Signature at the time of submission of their bid. 2) During the entire e-tender process, the bidders will remain completely anonymous to one another and also to everybody else.</p> <p>c) The e-tender floor shall remain open from the pre-announced date & time and for as much duration as mentioned above.</p> <p>d) All electronic bids submitted during the e-tender process shall be legally binding on the bidder. Any bid will be considered as the valid bid offered by that bidder and acceptance of the same by the Buyer will form a binding contract between Buyer and the Bidder for execution of supply. Such successful tenderer shall be called hereafter SUPPLIE</p>

	<p>e) It is mandatory that all the bids are submitted with digital signature certificate otherwise the same will not be accepted by the system. Buyer reserves the right to cancel or reject or accept or withdraw or extend the tender in full or part as the case may be without assigning any reason thereof.</p> <p>f) No deviation of the terms and conditions of the tender document is acceptable. Submission of bid in the e-tender floor by any bidder confirms his acceptance of terms & conditions for the tender.</p> <p>g) Unit of Measure (UOM) is indicated in the e-tender Floor. Rate to be quoted should be in Indian Rupee as per UOM indicated in the e-tender floor/tender document.</p>
09)	Any order resulting from this open e-tender shall be governed by the terms and conditions mentioned therein.
10)	No deviation to the technical and commercial terms & conditions are allowed.
11)	After submitting online bid, the bidder cannot access the tender, once it has been submitted with digital signature
12)	CCI has the right to cancel this e-tender or extend the due date of receipt of bid(s) without assigning any reason thereof.
13)	The online tender should be submitted strictly as per the terms and conditions and procedures laid down in the website etenders.gov.in/eprocure/app .
14)	The bidders must upload all the documents required as per terms of NIT. Any other document uploaded which is not required as per the terms of the NIT shall not be considered.
15)	The bid will be evaluated based on the filled-in technical & commercial formats.
16)	The documents uploaded by bidder(s) will be scrutinized. In case any of the information furnished by the bidder is found to be false during scrutiny, punitive action including suspension and banning of business can also be taken against defaulting bidders.
17)	Bidders are requested to read the vendor guide in the page etenders.gov.in/eprocure/app to familiarize themselves with the system before bidding.

For and on behalf of CCI Ltd,

HOD (MM)

CEMENT CORPORATION OF INDIA LIMITED
TANDUR CEMENT FACTORY

PART- III : SPECIAL TERMS AND CONDITIONS FOR INDUSTRIAL TUBE AXIAL FAN.

This tender contains Part-I and Part-II general terms, Part-III special terms and conditions, Part IV Specifications and price bid. Please read the Part – I (Instructions to tenderers), Part- II (General Terms & Conditions) available on tender portal of www.cciitd.in and Part- III (Special Terms & Conditions) & Part- IV (Technical specifications) of this tender and submit Declaration letter (Annexure-9), Preference to Make in India (annexure -10) in letter head duly signed and stamped in letter head of having read and understood the GTC along with Annexure 1 to 10.

In addition to the General Terms and conditions of the tender Part- I & II the following Special terms and conditions also apply to the contract for the supply of above category of material. These special terms and conditions if contradictory to any of the conditions given in Part-I & II shall prevail upon the conditions given therein:-

01) SPECIFICATION : As per Annexure VI Technical specifications .

02) PRICES: The rate should be quoted in prescribed price bid format in Indian Currency i.e. INR only as per Annexure enclosed. Price quoted other than INR will be rejected out rightly.

- a) Price should be quoted on FIRM basis with loading charges and other elements to be specified clearly. In case transportation will be arranged by supplier, the transportation charges may be quoted in lumpsum as per the price bid format. Material will be unloaded at our site and unloading charges shall be to CCI account. The price quoted should be firm and no revision in the price tendered will be permitted during the period of contract or in the extended period of the contract.

The L-1 rate will be arrived manually considering Item wise Landed cost of the material after GST input credit etc

03) GST-TDS @ 2 % will be deducted at source as TDS on GST

Incase GST is mentioned as '0'/kept blank in price bid, it shall be treated as inclusive and landed cost shall be arrived for comparison by debiting the input credit from the from the quoted rates

GST will be reimbursed to party after the same was paid by him to Govt. & upload the Invoice in GST portal

The Overall L-1 rate will be arrived considering landed cost of the material After GST Credit etc.

04) STATUTORY LEVIES:

It is the sole responsibility of the supplier that he complies with all statutory requirements regarding supply of equipment, payment of statutory levies etc. The supplier indemnifies CCI against any breach of statutory rules / their non- compliance.

05) DELIVERY SCHEDULE:

Material is to be supplied within 4 to 6 weeks from the date of placement of LOI / Order

06) LIQUIDATED DAMAGES:

(a) If the value of order is \leq Rs. 10.0 lakhs or duration is \leq 3 months then L.D is to be recovered 0.5% per week or part thereof, subject to maximum limit of 10% of the total value of the order.

(b) If the value of order is $>$ Rs. 10.0 lakhs or duration is $>$ 3 months L.D is to be recovered is 0.5% per fortnight or part thereof, subject to maximum limit of 5% of the total value of the order

07) Payment terms:

90% value of the order within 30 days of successful completion of supply and balance 10% after successful completion of guarantee/ warranty period. This 10 % can also be paid against submission of Bank Guarantee for equivalent amount towards performance Guarantee

08) EARNEST MONEY DEPOSIT (EMD) @ Rs. 12.000/- by NEFT/RTGS in favor of M/s. CEMENT CORPORATION OF INDIA LIMITED, Bank: SBI, Karankote Branch, Bank A/c. : 62017406489, IFSC Code: SBIN0020446

09) SECURITY DEPOSIT

Successful tenderer(s) shall have to furnish a Security Deposit equivalent to 05% (Five percent) value of the order by way of Demand Draft / Bank Guarantee (In CCI's format) in terms of Clause No. 2 of Part- II of the tender documents for satisfactory completion of the contract. S.D. will be refunded after 3 months of successful completion of supplies.

10) PERFORMANCE GUARANTTEE

Successful tenderer(s) shall have to furnish 10% (Ten percent) value of the order by way of Bank Guarantee towards performance Guarantee for satisfactory performance of the equipments supplied. The P.G. shall be refunded after successful completion of guarantee/ Warranty period. The claim period shall be within 3 months after warranty period.

- 11) Guarantee/Warrantee: 12 months from the date installation or 18 months from the date of Supply, Whichever is earlier.
- 12) CCI has the rights to place "**Repeat Order**" at the same rate, terms & conditions of original order with the consent of the supplier

CEMENT CORPORATION OF INDIA LIMITED
TANDUR CEMENT FACTORY

TCF/MM/4044/23/RR

PRICE BID FORMAT

/ANNEXURE-XIII/

Name of the Bidder/ Bidding Firm/ Company:	
--	--

PRICE SCHEDULE
The Overall L-1 rate will be arrived manually considering landed cost of the material after GST Input credit etc

NUMBER #	TEXT #	NUMBER #	TEXT #	NUMBER #	NUMBER #	NUMBER #	NUMBER #	NUMBER #	NUMBER #	NUMBER #	TEXT #
Sl. No.	Item Description	Quantity	Units	Unit Rate Including freight charges	GST in Percentage (%)	HSN Code of Item	TOTAL AMOUNT Without Taxes	TOTAL AMOUNT With Taxes	TOTAL AMOUNT In Words		
1	2	4	5	7	8	9	13	14	15		
	SUPPLY OF INDUSTRIAL TUBE AXIAL FAN										
1.01	Energy Efficient Industrial Tube Axial Fan for 3200 KW Motor Cooling Duct as per given specification.	4.00	Nos				0.00	0.00	INR Zero Only		
Total in Figures							0.00	0.00	INR Zero Only		
Quoted Rate in Words							INR Zero Only				

PLACE: _____

DATE: _____

SIGNATURE OF THE TENDERER

BLOWER CASING WITH FLANGE DIAGRAM FOR 3200KW MOTOR

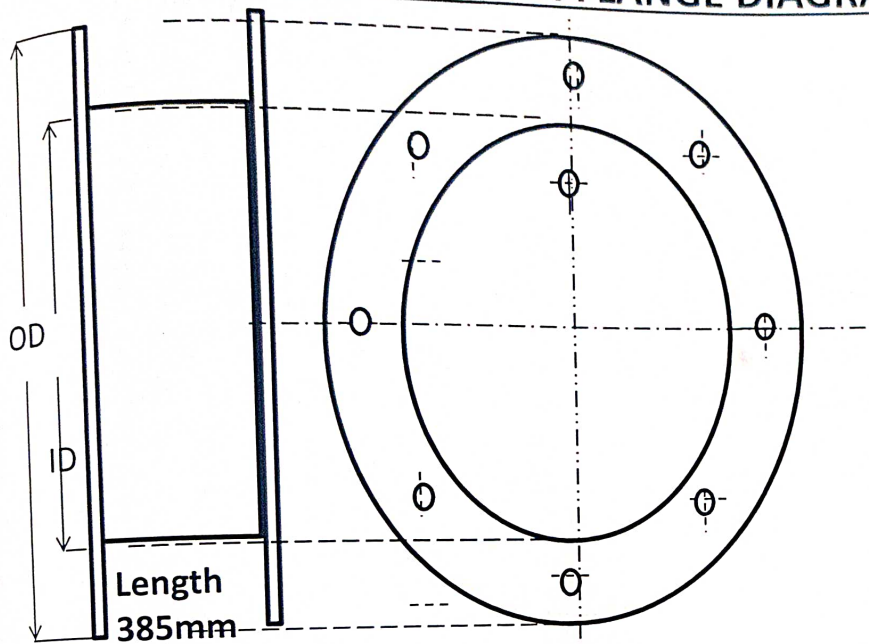

All dimensions are in mm

A) FLANGE Dimensions

- 1) OD : 575
- 2) ID : 510
- 3) PCD : 540
- 4) No of \varnothing : 12
- 5) \varnothing : 12
- 6) Qty : 04 No's

- A SPECIFICATIONS :** High Efficient Cooling Blower Unit with complete casing, grill, fan and motor, . for 3200kw Ht motors Make, Type: IGH5254-02F, SRIM should have the following specifications:
- It should deliver the pressure of 1300 N/m^2 having volumetric flow rate of $7-10 \text{ m}^3/\text{sec}$
 - The casing should be made up of M.S. Material with casing 3-5mm thickness and flange 3-5mm thickness.
 - Impeller should be energy efficient as per latest
 - It should directly driven by a suitable constant speed AC motors of Siemens / BBL / ABB / CGL make only.
 - The AC motor should be of foot mounting with cast iron body, protection IP 65 & IE3, 2- Pole 3.7/5.5kw as per latest amendment of Indian standards and motor terminals should mounted with terminal box on casing
 - Fan should be run both clockwise and anti clock wise direction .
 - The outlet should match to the existing inlet duct of the SRIM and as per diagram

[Handwritten signature]

BLOWER CASING WITH FLANGE DIAGRAM FOR 2000KW MOTOR

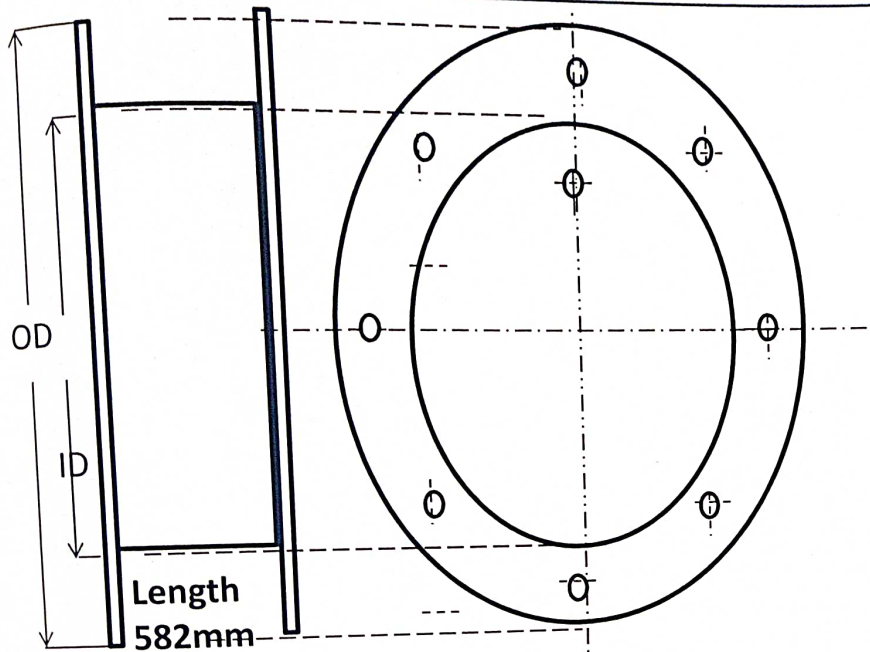

All dimensions are in mm

A) FLANGE Dimensions

- 1) OD : 710
- 2) ID : 610
- 3) PCD : 665
- 4) No of \emptyset : 08
- 5) \emptyset : 14
- 6) Qty : 04 No's

A SPECIFICATIONS : : High Efficient Cooling Blower Unit with complete casing, grill, fan and motor, . for 2000kw Ht motors Make, Type: IGH5254-02H, SRIM should have the following specifications:

- It should deliver the pressure of 1300 N/m² having volumetric flow rate of 5-7 m³/sec
- The casing should be made up of M.S. Material with casing 3-5mm thickness and flange 3-5mm thickness.
- Impeller should be energy efficient as per latest
- It should directly driven by a suitable constant speed AC motors of Siemens / BBL / ABB / CGL make only.
- The AC motor should be of foot mounting with cast iron body, protection IP 65 & IE3, 2- Pole 3.7/5.5kw as per latest amendment of Indian standards and motor terminals should mounted with terminal box on casing
- Fan should be run both clockwise and anti clock wise direction .
- The outlet should match to the existing inlet duct of the SRIM and as per diagram

(Handwritten signature)